

World Class Power Solutions



Industry

INVERTRONIC compact
Modular, Single Phase Inverters



INVERTRONIC compact

Cost Saving Power Protection Availability

Mains failure and mains disturbances may cause serious problems

More and more mission critical loads for industrial and commercial applications require a smooth and uninterrupted supply of electricity.











On the public network, major loads as well as lightning strikes, generate dynamic over voltages, under voltages, sags/brownouts and transients.

Invertronic compact inverter systems ensure continuous power protection availability

Benning's new advanced INVERTRONIC compact single phase inverter systems provide continuous and high quality AC power for mission critical loads in the industrial and commercial market place.

The INVERTRONIC compact inverter modules offer a very flexible platform to design compact AC/AC power solutions in combination with the modular rectifier range 3000I and 12000I.

(see pages 5 & 6 for examples)

Voltage Phenomenon	Time	e.g.
1. Outage - blackouts	> 10 ms	
2. Sags/brownouts	< 16 ms	
3. Dynamic overvoltage	4...16 ms	
4. Undervoltage	continuous	
5. Overvoltage	continuous	
6. Transients (Surge)	< 4 ms	
7. Lightning	sporadic	
8. Voltage distortion HF (Burst)	periodically	
9. Voltage harmonics	continuous	
10. Frequency variations	sporadic	

published by ZVel: UPS Guide

Table of main disturbances

Malfunctions in the public network (see table of mains disturbances above) may cause hardware failure, disruption of critical loads, unplanned production downtime or loss of communication.

Inverter systems are often the perfect choice to supply reliable and conditioned AC power to mission critical applications.



Fig. 1: 19" Sub-rack with 3 INVERTRONIC compact inverters, static and manual bypass



Fig. 2: 19" Sub-rack with 5 INVERTRONIC compact inverters

The INVERTRONIC compact range consists of the following system components:

1. 19" sub-rack

The 19" sub-rack is designed to accommodate the INVERTRONIC modules and can be integrated into 19" floor standing or wall mounted cabinets.

The following sub-rack versions are available:

- Sub-rack with back plane connections for up to 3 inverter modules, one static bypass module and a manual bypass. (fig. 1)
- Sub-rack with back plane connections for up to 5 inverter modules. (fig. 2)

INVERTRONIC compact

Modular Design, Multiple System Integration

2. Parallel operating Inverter modules

INVERTRONIC inverter modules are available for use with DC input voltages of 110V or 220V. The standard AC output voltage is 230V, but 220V and 240V are selectable. Each inverter module can supply 1.5kVA rated output power.

The hot-plug design of the inverter modules together with the dimensions of 1/5 19 inch width and 3U height allows the accommodation into 19 inch 3U sub-racks.

3. Static bypass switch

The static bypass switch increases the availability of the inverter system and provides security during overload or short circuit.

The bypass switch transfers the load to the mains if the inverter output deviates outside the acceptable tolerances for both, voltage and frequency, caused by short circuit, overload, or inverter failure.

Automatic transfer of the load back to the inverter is made after the inverter output has returned to within tolerance.

The transfer time is less than 2ms.

The static bypass has the same dimensions as the inverter modules and can be integrated into the 19 inch sub-rack. (Fig.5).

4. Manual bypass switch

The additional integrated manual bypass switch is located beside the static bypass switch and allows the manual transfer of the load to the mains or to the inverter output.

This switch allows the inverter modules and the static bypass module to be bypassed for service reasons.

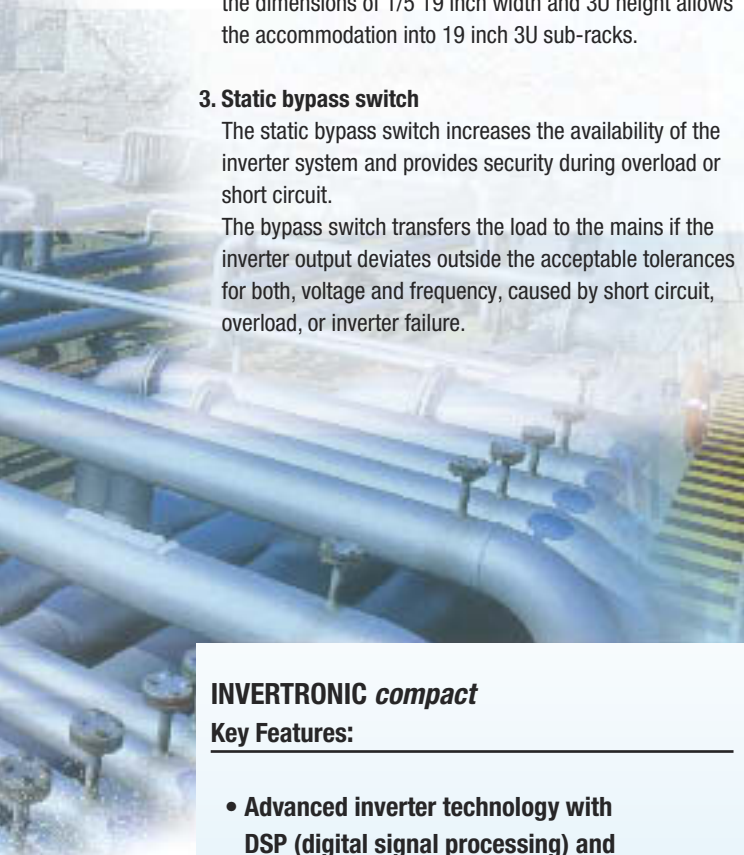

INVERTRONIC compact

Key Features:

- Advanced inverter technology with DSP (digital signal processing) and IGBT/MOSFET semiconductors
- Scalable and flexible single phase inverter system with hot -plug inverter modules for parallel operation
- Short MTTR (Mean Time To Repair)
Replacement of modules without any load break
- The combination with Benning's modular rectifier range, allows the realisation of very compact AC-AC systems
- High efficiency even at partial loads, means low operating costs
- N+1 redundant configuration ensures continuous availability
- Excellent dynamic response
- High power density with low volume and weight

Block diagram of the modular construction of INVERTRONIC compact inverter systems

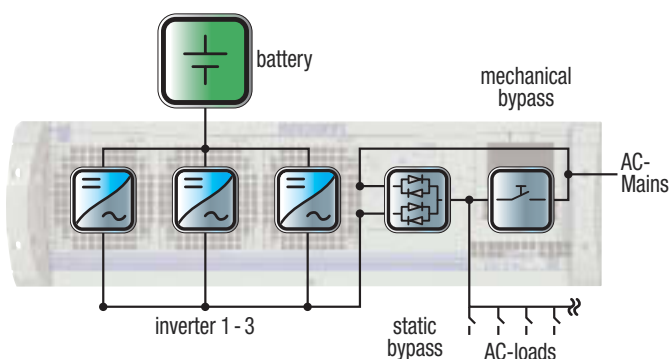

Fig. 3 (above): Sub-rack with 3 inverters, static bypass switch and manual bypass switch

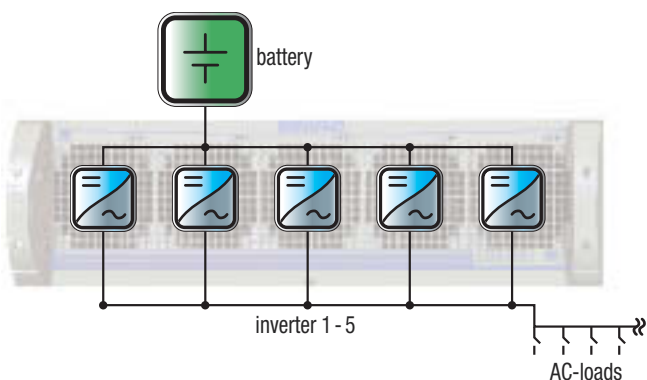

Fig. 4: Sub-rack with 5 inverters, without bypass switch



INVERTRONIC compact

Plug and Play Means Lower Operating Costs

Fig. 5: 19" Sub-rack with 3 inverters, static bypass and manual bypass, output voltage 230 V AC, output power 4.5 kVA



Fig. 6: 19" Sub-rack with 5 inverters, output voltage 230 V AC, output power 7.5 kVA

INVERTRONIC compact Redundancy Ensures Higher Availability

Multiple system integration

The modular design of the INVERTRONIC *compact* inverters allows flexible configurations of custom designed DC/AC or AC/AC (UPS) power supply solutions.



Fig. 7: Inverter cabinet with
8 inverter modules, static and manual bypass.
Total AC output power 12 kVA

INVERTRONIC compact Monitoring & Remote Management with MCU 2500

Figs 7 & 8, show different sizes of cabinets with sub-racks for inverters only and a combination of inverters and rectifiers.

The integration of battery and load fuses/breakers is also possible.

Monitoring system MCU 2500

The Monitoring system MCU 2500 allows local or remote operation of the INVERTRONIC compact systems.

The display and operation unit mounted on the front door of the system cabinet consists of liquid crystal display, 17 LED's and 4 push buttons and allows local operation of the power system.

Remote control and monitoring is possible using modem, Ethernet, Web, SNMP, MODbus or Profibus. (Fig10)



Fig. 8: Inverter- rectifier cabinet with:
3 inverter modules, static and manual bypass
Total AC output power 4.5 kVA
5 rectifier modules output voltage 220V DC, output current 50A DC

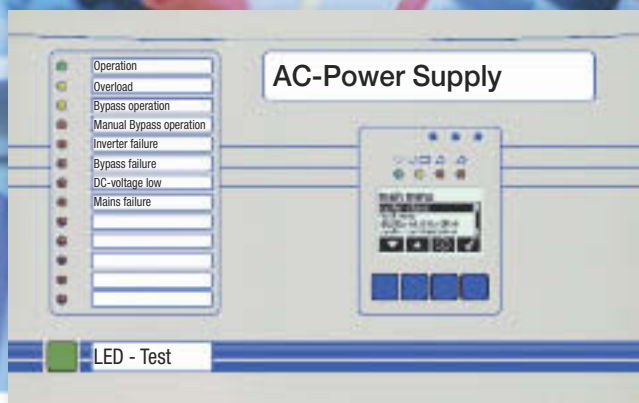
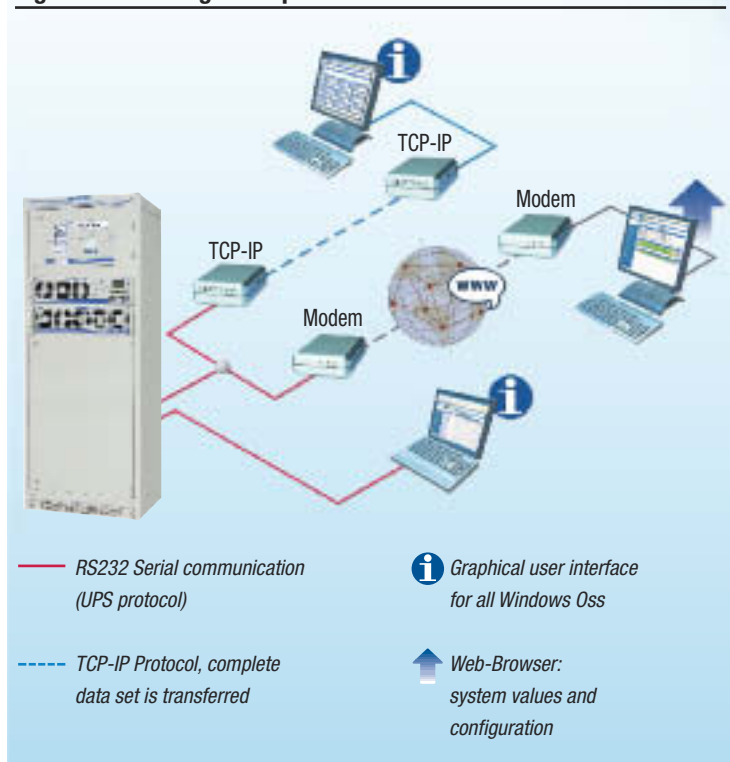

Fig. 9: Monitoring and control unit

Fig. 10: Monitoring concept of the MCU 2500



Technical Specification

INVERTRONIC compact

Technical Specification

Inverter

Rated output power at (cos φ = 0,8) DC-Input 110 V/220 V	[kVA]	1.5	3.0	4.5	6.0	7.5
No. of modules		1	2	3	4	5

Inverter input

Input voltage range	[%]	-15 to +20				
Permitted ripple Voltage	[%]	< 5 eff.				
Current input at 110 V DC	[A]	12	24	36	48	60
Current input at 220 V DC	[A]	6	12	18	24	30

Inverter output

Output voltage	[V]	220/230/240 1-ph., N, PE (selectable)				
Voltage tolerance						
- static	[%]	± 1				
- dynamic	[%]	=<10 @100% load step				
Regulation time	[msec]	≤ 25				
Output current at 230 V AC	[A]	6.5	13.0	19.5	26.0	32.5
Motorload		100 % (beware of starting current)				
Overload behaviour:	[%]	2.0 x I - nom for 4 sec., 1.2 x I - nom for 60 sec., then switch off				
Short-circuit current	[A]	2.1 x I - nom for 4 sec.				
Output frequency	[Hz]	50 (60) ± 0.1 % oscillator or mains synchronised				
Synchronisation range	[Hz]	50 (60) ± 5 % (selectable)				
Wave form		sinusoidal				
Distortion factor	[%]	≤ 2 with linear load, ≤ 5 with non linear load according to EN 50091-1-1				
Efficiency at nominal output power and input voltage DC 110/220 V	[%]	≥ 91.5				

Static bypass

Rated output power	[kVA]	23 (at 230 V AC)
--------------------	-------	------------------

Input

DC voltage	[V]	93 to 270 DC
*Mains voltage	[V]	220/230/240
Tolerance	[%]	±15
*Mains frequency	[Hz]	50/60
	[%]	max. ±5; Inverter synchronisation range
*Inverter output voltage	[V]	220/230/240 AC

Output

Max. output current	[A]	100
*Nominal output voltage	[V]	220/230/240 AC
Voltage tolerance	[%]	max. ±15 mains operation, max. ±1 inverter operation
*Nominal output frequency	[Hz]	50/60
Max. frequency tolerance	[%]	±5 (±0.1 oscillator controlled)
Power factor	[cos φ]	0.7 ind. to 0.8 cap.
Overload	[%]	120 for 10 min.
Transfer time	[msec]	typ. 2 in accordance with DIN VDE 0558 Part 5, IEC 146-4
*Supply priority		Inverter/mains priority

(*: These adjustments can be made directly on the unit.)

Others

EMC		in according with (EN 55022)
Noise level (at 75 – 100 % load)	[dB(A)]	approx 65
Cooling		forced cooling with speed controlled fans at air inlet
Permitted ambient temperature	[°C]	0- 40°C (up to 55°C with derating 2,5 % PN/°C)
Permitted storage temperature	[°C]	-25 to +70
Relative humidity	[%]	5 – 95 without condensation
Installation altitude at nom. load	[m]	1.000 m without power reduction
Protection		IP 20 in accordance with DIN 40050
Painting		RAL 7035, structured paint finish (frontplate)
Dimensions, Sub-rack		3 U x 19" x 300 mm (H x W x D)
Weight:		
- Sub-rack with 3 inverters, bypass and manual bypass	[kg]	21.5
- Sub-rack with 5 inverters	[kg]	23.2

Specifications are subject to change without notice.



www.benning.de

BENNING worldwide

Austria

Benning GmbH Elektrotechnik und Elektronik
Eduard-Klinger-Str. 9
A-3423 St. Andrä-Wördern
Tel. 0 22 42 / 3 24 16-0
Fax 0 22 42 / 3 24 23
E-Mail: info@benning.at

Belarus

IOOO BENNING Belarus
ul. Derzinskogo, 50
BY-224030, Brest
Tel. 0162 / 22 07 21
Fax 0162 / 22 07 21
E-Mail: info@benning.brest.by

Belgium

Benning Belgium
Power Electronics
Z. 2 Essenestraat 16
B-1740 Ternat
Tel. 02 / 58 287 85
Fax 02 / 58 287 69
E-Mail: info@benning.be

Croatia

Benning Zagreb d.o.o.
Trnjanska 61
HR-10000 Zagreb
Tel. 1 / 63 12 280
Fax 1 / 63 12 289
E-Mail: info@benning.hr

Czech Republic

Benning CR s.r.o.
Zahradní ul. 894
CZ-293 06 Kosmonosy
(Mladá Boleslav)
Tel. 3 26 72 10 03
Fax 3 26 72 25 33
E-Mail: benning@benning.cz

France

Benning Conversion d'énergie
43, avenue Winston Churchill
B.P. 418
F-27404 Louviers Cedex
Tél. 0 / 2.32.25.23.94
Fax 0 / 2.32.25.08.64
E-Mail: info@benning.fr

Germany

Benning Elektrotechnik und Elektronik
GmbH & Co.KG
Factory I: Münsterstr. 135-137
Factory II: Robert-Bosch-Str. 20
D-46397 Bocholt
Tel. 0 28 71/ 93-0
Fax 0 28 71/ 9 32 97
E-Mail: info@benning.de

Great-Britain

Benning Power Electronics (UK) Ltd.
Oakley House
Hogwood Lane
Finchampstead
GB-Berkshire
RG 40 4QW
Tel. 0118 9731506
Fax 0118 9731508
E-Mail: info@benninguk.com

Hungary

Benning Kft.
Power Electronics
Rákóczi út 145
H-2541 Lábattlan
Tel. 033 / 50 76 00
Fax 033 / 50 76 01
E-Mail: benning@vnet.hu

Italy

Benning Conversione di Energia S.r.L.
Via 2 Giugno 1946, 8/B
I-40033 Casalecchio di Reno (BO)
Tel. 0 51 / 75 88 00
Fax 0 51 / 61 67 655
E-Mail: info@benningitalia.com

Netherlands

Benning NL
Power Electronics
Peppelkade 42
NL-3992 AK Houten
Tel. 0 30 / 6 34 60 10
Fax 0 30 / 6 34 60 20
E-Mail: info@benning.nl

Poland

Benning Power Electronics Sp. z o.o.
Korczyńska 30
PL-05-503 Głusków
Tel. 0 22 / 7 57 84 53 / 7 57 36 68-70
Fax 0 22 / 7 57 84 52
E-Mail: biuro@benning.biz

P. R. China

Benning Power Electronics (Beijing) Co., Ltd.
Tongzhou Industrial Development Zone
1-B BeiEr Street
CN-101113 Beijing
Tel. 010 61568588
Fax 010 61506200
E-Mail: info@benning.cn

Russian Federation

000 Benning Power Electronics
Moscow region,
Domodedovskiy district,
Domodedovo, Severny zone,
Tel. (495) 967 68 50
Fax (495) 967 68 51
E-Mail: benning@benning.ru

Slovakia

Benning Slovensko, s.r.o.
Kukuričná 17
SK-83103 Bratislava
Tel. 02 / 44459942
Fax 02 / 44455005
E-Mail: benning@benning.sk

South America

Benning Office South America
Lavalle 637
AR-1876 Bernal, Buenos Aires
Argentina
Tel. 54/ 911 5498 2515
E-Mail: info-argentina@benning.es

South East Asia

Benning Power Electronics Pte Ltd
85, Defu Lane 10
#05-00
SGP-Singapore 539218
Tel. (65) 6844 3133
Fax (65) 6844 3279
E-Mail: sales@benning.com.sg

Sweden

Benning Sweden AB
Box 990, Hovslagarev. 3B
S-19129 Sollentuna
Tel. 08 / 6239500
Fax 08 / 969772
E-Mail: power@benning.se

Switzerland

Benning Power Electronics GmbH
Industriestrasse 6
CH-8305 Dietlikon
Tel. 044 / 8057575
Fax 044 / 8057580
E-Mail: info@benning.ch

Spain

Benning Conversión de Energía S.A.
C/Pico de Santa Catalina 2
Pol. Ind. Los Linares
E-28970 Humanes, Madrid
Tel. 91 / 6048110
Fax 91 / 6048402
E-Mail: benning@benning.es

Ukraine

Benning Power Electronics
3 Sim'yi Sosnynykh str.
UA-03148 Kyiv
Tel. 044 / 501 40 45
Fax 044 / 273 57 49
E-Mail: info@benning.ua

U.S.A.

Benning Power Electronics, Inc.
11120 Grader Street
USA-Dallas, TX 75238
Tel. 214 5531444
Fax 214 5531355
E-Mail: sales@benning.us

ISO
9001

ISO
14001

SCC



BENNING