

Excellent Technology, Efficiency and Quality



Industry

DC/DC converters
in modular rack-mounted design
Series 3000 IDC



Modular DC/DC converters

high system availability thanks to modular power supplies

Modular DC/DC converters

For many years, BENNING has been supplying modular rectifier and inverter systems for providing power to electronic systems in industry, telecommunications and information technology. These modular systems have proved their worth extremely effectively thanks to their high availability and excellent service friendliness.

The DC/DC converters described below ideally complement these modular systems, as they have the same mechanical platform and the front plate design matches other modules in the range.

Combinations of all three series of units can therefore easily be accommodated in common system cabinets.

The block circuit diagram (Fig. 1) shows the principle of the modular architecture of all three series of units in a power supply system with modular rectifiers, modular inverters and modular DC/DC converters.

Fig. 2 shows an example of a modular power supply system built into a system cabinet with two battery-backed direct voltages and one battery-backed alternating voltage. Monitoring is by means of the MCU 2500 with the indication and control unit fitted in the front door.



Fig. 1: Block circuit diagram of the modular architecture of a power supply system with rectifiers, inverters and DC/DC converters

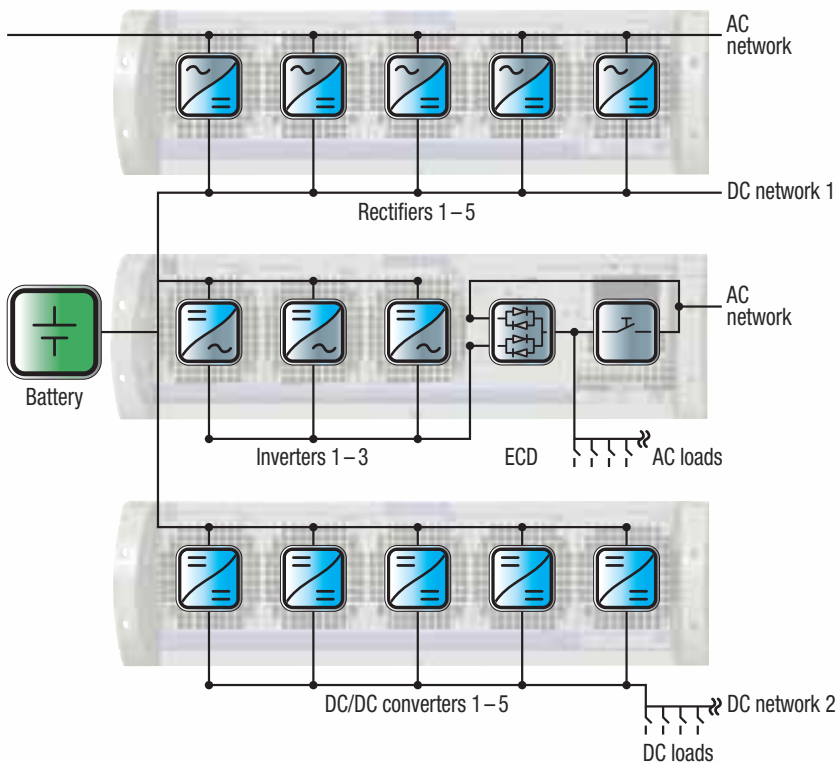

Fig. 2: Combined power supply system (similar to block circuit diagram Fig. 1)

Modular DC/DC converters

Wide-range voltage input ensures flexibility of use

DC/DC converters in modular rack-mounted design offer flexible power adaptation (scalability), high availability, good energy efficiency and flexibility of use

The large 85 – 240 V DC input voltage range of the modular DC/DC converters allows the units to be used both for 110 V and for 220 V DC networks. Depending on the type, units can be supplied for DC output voltages of 24 V, 48 V, 60 V, 110 V or 220 V.

The DC/DC converters consist of power modules with operationally safe hot-plug rack-mounted design. The appropriate number are fitted in 19" module racks depending on the power required (see Fig. 3 and 4).

DC/DC converter modules are available for the following input and output voltages

DC input voltage 220 V

DC output values: 24 V – 50 A, 48 V – 40 A, 60 V – 40 A, 110 V – 20 A, 220 V – 10 A

DC input voltage 110 V

DC output values: 24 V – 27 A, 48 V – 22 A, 60 V – 22 A, 110 V – 11 A, 220 V – 5.5 A



The power modules are connected in parallel within the module rack enabling the output power to be flexibly scaled and redundant systems to be built up (e.g. n+1 redundancy).

The power modules are distinguished by excellent efficiency and high power density, and require just 3 U of vertical rack space in 19" equipment cabinets.

All DC/DC converters are galvanically isolated and can be used with or without a parallel-connected battery.

The user-friendly hot-plug design enables DC/DC converter modules to be quickly and easily replaced or installed during operation.

A complete 19" DC/DC converter plug-in unit consists of a maximum of five DC/DC converter modules and, for example, has an output current of 250 A at an input voltage of 220 V and an output voltage of 24 V.

When four modules are fitted, the MCU 2500 display and remote monitoring system can also be installed (see Fig. 3).

Main features of the modular DC/DC converters

- Low volume and weight
- Low output ripple
- System power scalability
- Hot-Plug rack-mounted design for reliable operation
- Easy design of redundant system solutions
- High energy capability due to good efficiency
- Wide-range voltage input from 85 to 265 V DC
- Galvanic isolation between input and output
- Control, monitoring and indication with MCU 2500



Modular DC/DC converters high power density and excellent efficiency

Fig. 3: 19" DC/DC converter plug-in unit with 4 TEBECHOP 3000 IDC modules and MCU 2500 remote monitoring, output voltage 110 V, output current 80 A

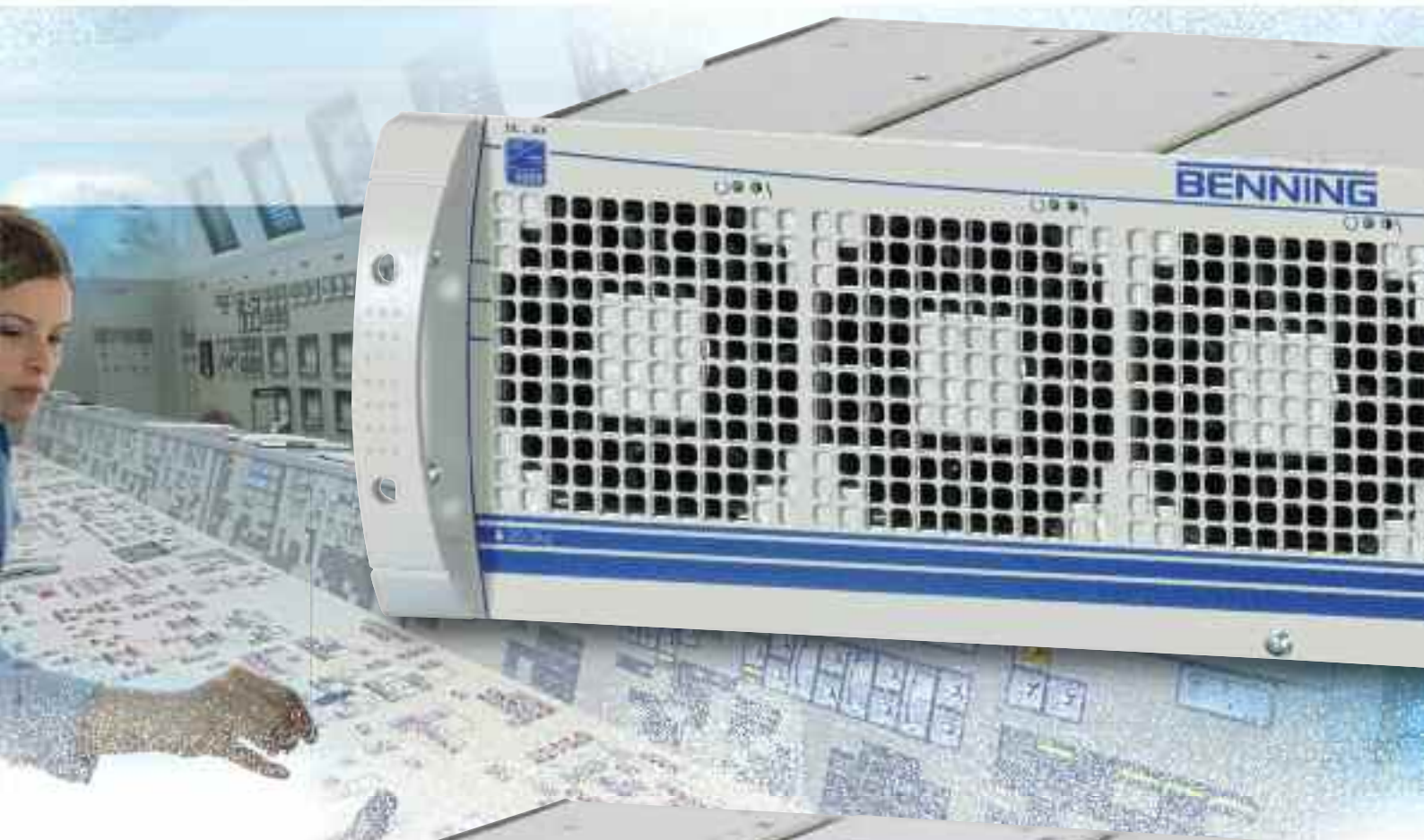

Fig. 4: 19" DC/DC converter plug-in unit with 5 TEBECHOP 3000 IDC modules, output voltage 24 V, output current 250 A

Modular DC/DC converters *compact volume and low weight*



Fig. 5: System cabinet with 2 modular DC/DC converter plug-in units, output voltage 220 V, output current 100 A

Modular DC/DC converters comprehensive display and monitoring concept

System cabinets

The BENNING range of system cabinets provides a number of options for building up modular DC/DC converter systems. In the standard version, the DC/DC converter system cabinet comprises the incoming supply panel, one or more DC/DC converter panels with module racks, and the output panel.

Included in the incoming supply panel are two-pole circuit breakers for protecting the DC/DC converter modules on the input side.

Depending on the required DC power, the DC/DC converter panel is fitted with one or more 19" module racks for mounting the DC/DC converter modules.

Single-pole or two-pole circuit breakers are fitted in the output panel. These circuit breakers can be provided with auxiliary or signal contacts (option).

Capacitor banks, which guarantee safe tripping of the load fuses in the event of a possible short-circuit, can be fitted in the output panel as an option.



Fig. 6: Internal view of a system cabinet with MCU 2500 and with DC/DC converters fitted

MCU 2500 remote monitoring system

The microprocessor controlled MCU 2500 remote monitoring system can be supplied as a sub-module (1/5 - 19") for fitting in the 19" system module rack (see Fig. 3), or as a panel-mounted version with the display and control unit mounted in the front door of a system cabinet (see Fig. 5).

The MCU 2500 controls and monitors the DC/DC converter system, wherein the system data can be set up and recorded both locally and by means of the remote monitoring function.

With remote monitoring, data can be transmitted by modem, Ethernet, WEB, SNMP, MODBus or Profibus (see Fig. 8).

The MCU 2500 is extremely versatile due to the large number of additional modules available for monitoring and recording measurements, and can be adapted to suit many customer specifications.

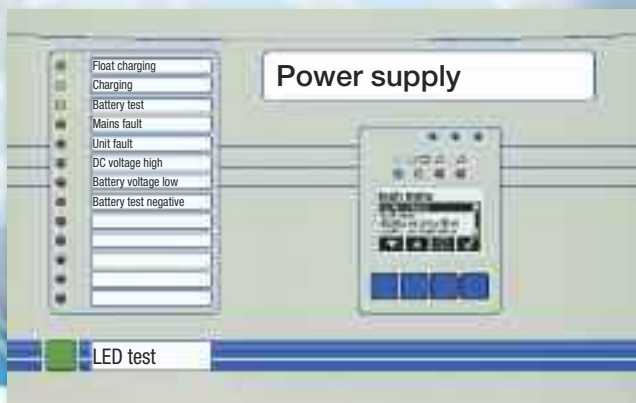
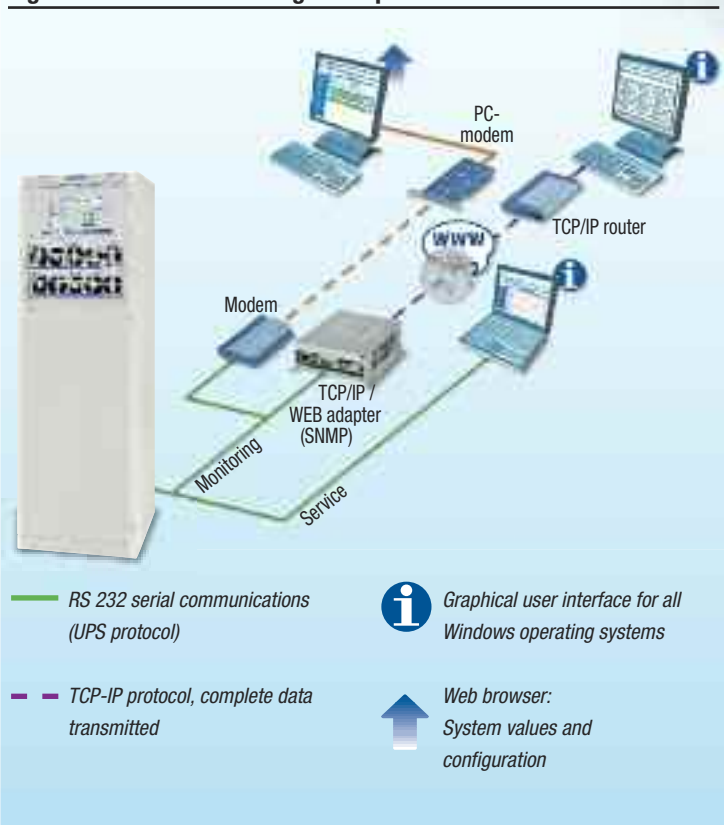

Fig. 7: Display and control unit

Fig. 8: MCU 2500 monitoring concept



- RS 232 serial communications (UPS protocol)
- - - TCP-IP protocol, complete data transmitted
- Graphical user interface for all Windows operating systems
- Web browser: System values and configuration

Technical data

DC/DC converters

Number of DC/DC converter modules		1	2	3	4	5
Input						
DC input voltage	[V]	110				
Permissible voltage range	[V]	85 – 265				
Output						
Output current at						
24 V	[A]	27	54	81	108	135
48 V	[A]	22	44	66	88	110
60 V	[A]	22	44	66	88	110
110 V	[A]	11	22	33	44	55
220 V	[A]	5.5	11	165	22	27.5
Input						
DC input voltage	[V]	220				
Permissible voltage range	[V]	85 – 265				
Output						
Output current at						
24 V	[A]	50	100	150	200	250
48 V	[A]	40	80	120	160	200
60 V	[A]	40	80	120	160	200
110 V	[A]	20	40	60	80	100
220 V	[A]	10	20	30	40	50
Characteristic		IU				
Output voltage	[V]	24	48	60	110	220
adjustable	[%]	± 25				
Short-circuit behaviour	[%]	> 2.0 x I _N for max. 2 s, then shut down				
Voltage stability						
steady-state	[%]	± 1 (typically ± 0.5 %)				
dynamic	[%]	± 4 (load Δ 10 % - 90 % - 10 %)				
Settling time	[ms]	< 2 (load Δ 10 % - 90 % - 10 %)				
Efficiency	[%]	85 – 93				
Residual ripple	[%]	< 1				
Radio interference factor		Class B to EN 55022				
Protection class		1 to IEC 60950, EN 60950, UL 1950				
Protection category		IP 20				
Ambient temperature	[°C]	-5 to +40				
Installation altitude	[m]	up to 1000 m ASL, at > 1000 m -10 % per 1000 m				
Humidity class		F to DIN 40040				
Cooling		Fan, monitored				
Visual displays (LED)						
Mains		red/green flashing				
Overvoltage		red flashing				
Running		green				
Fault		red				
Fuse		red flashing				
Dimensions 19" full module						
Height (front plate)	[mm]	133				
Width (front plate)	[mm]	483				
Depth	[mm]	400				
Weight	[kg]	14	17	20	23	26

Subject to technical changes

BENNING worldwide

ISO
9001

ISO
14001

SCC

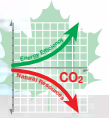

Austria

Benning GmbH
Elektrotechnik und Elektronik
Eduard-Klinger-Str. 9
3423 ST. ANDRÄ-WÖRDERN
Tel.: +43 (0) 22 42 / 3 24 16-0
Fax: +43 (0) 22 42 / 3 24 23
E-mail: info@benning.at

Belarus

1000 BENNING Belarus
ul. Derzinskogo, 50
224030, BREST
Tel.: +375 (0) 1 62 / 22 07 21
Fax: +375 (0) 1 62 / 22 07 21
E-mail: info@benning.brest.by

Belgium

Benning Belgium
Power Electronics
Z. 2 Essenestraat 16
1740 TERNAT
Tel.: +32 (0) 2 / 5 82 87 85
Fax: +32 (0) 2 / 5 82 87 69
E-mail: info@benning.be

Croatia

Benning Zagreb d.o.o.
Trnjanska 61
10000 ZAGREB
Tel.: +385 (0) 1 / 6 31 22 80
Fax: +385 (0) 1 / 6 31 22 89
E-mail: info@benning.hr

Czech Republic

Benning CR s.r.o.
Zahradní ul. 894
293 06 KOSMONOSY
(Mladá Boleslav)
Tel.: +420 / 3 26 72 10 03
Fax: +420 / 3 26 72 25 33
E-mail: odbyt@benning.cz

France

Benning
conversion d'énergie
43, avenue Winston Churchill
B.P. 418
27404 LOUVIERS CEDEX
Tel.: +33 (0) / 2 32 25 23 94
Fax: +33 (0) / 2 32 25 08 64
E-mail: info@benning.fr

Germany

Benning Elektrotechnik und Elektronik
GmbH & Co. KG
Factory I: Münsterstr. 135-137
Factory II: Robert-Bosch-Str. 20
46397 BOCHOLT
Tel.: +49 (0) 28 71 / 93-0
Fax: +49 (0) 28 71 / 9 32 97
E-mail: info@benning.de

Great-Britain

Benning Power Electronics (UK) Ltd.
Oakley House
Hogwood Lane
Finchampstead
BERKSHIRE
RG 40 4QW
Tel.: +44 (0) 1 18 / 9 73 15 06
Fax: +44 (0) 1 18 / 9 73 15 08
E-mail: info@benninguk.com

Hungary

Benning Kft.
Power Electronics
Rákóczi út 145
2541 LÁBATLAN
Tel.: +36 (0) 33 / 50 76 00
Fax: +36 (0) 33 / 50 76 01
E-mail: benning@vnet.hu

Italy

Benning Conversione di Energia S.r.l.
Via 2 Giugno 1946, 8/B
40033 CASALECCHIO DI RENO (BO)
Tel.: +39 0 51 / 75 88 00
Fax: +39 0 51 / 6 16 76 55
E-mail: info@benningitalia.com

Netherlands

Benning NL
Power Electronics
Peppelkade 42
3992 AK HOUTEN
Tel.: +31 (0) 30 / 6 34 60 10
Fax: +31 (0) 30 / 6 34 60 20
E-mail: info@benning.nl

Poland

Benning Power Electronics Sp. z o.o.
Korczyńska 30
05-503 GŁOSKÓW
Tel.: +48 (0) 22 / 7 57 84 53
Fax: +48 (0) 22 / 7 57 84 52
E-mail: biuro@benning.biz

P. R. China

Benning Power Electronics (Beijing) Co., Ltd.
Tongzhou Industrial Development Zone
1-B BeiEr Street
101113 BEIJING
Tel.: +86 (0) 10 / 61 56 85 88
Fax: +86 (0) 10 / 61 50 62 00
E-mail: info@benning.cn

Russian Federation

Russian Federation
000 Benning Power Electronics
Schelkovskoye chausse 5
105122 MOSCOW
Tel.: +7 4 95 / 9 67 68 50
Fax: +7 4 95 / 9 67 68 51
E-mail: benning@benning.ru

Slovakia

Benning Slovensko, s.r.o.
Kukuríčná 17
83103 BRATISLAVA
Tel.: +421 (0) 2 / 44 45 99 42
Fax: +421 (0) 2 / 44 45 50 05
E-mail: benning@benning.sk

South East Asia

Benning Power Electronics Pte Ltd
85, Defu Lane 10
#05-00
SINGAPORE 539218
Tel.: +65 / 68 44 31 33
Fax: +65 / 68 44 32 79
E-mail: sales@benning.com.sg

Spain

Benning Conversión de Energía S.A.
C/Pico de Santa Catalina 2
Pol. Ind. Los Linares
28970 HUMANES, MADRID
Tel.: +34 91 / 6 04 81 10
Fax: +34 91 / 6 04 84 02
E-mail: benning@benning.es

Sweden

Benning Sweden AB
Box 990, Hovslagarev. 3B
19129 SOLLENTUNA
Tel.: +46 (0) 8 / 6 23 95 00
Fax: +46 (0) 8 / 96 97 72
E-mail: power@benning.se

Switzerland

Benning Power Electronics GmbH
Industriestrasse 6
8305 DIETLIKON
Tel.: +41 (0) 44 / 8 05 75 75
Fax: +41 (0) 44 / 8 05 75 80
E-mail: info@benning.ch

Ukraine

Benning Power Electronics
3 Sim'yi Sosninykh str.
03148 KYIV
Tel.: +380 (0) 44 / 5 01 40 45
Fax: +380 (0) 44 / 2 73 57 49
E-mail: info@benning.ua

U.S.A.

Benning Power Electronics, Inc.
11120 Grader Street
DALLAS, TX 75238
Tel.: +1 2 14 / 5 53 14 44
Fax: +1 2 14 / 5 53 13 55
E-mail: sales@benning.us